

Good Water Warehouse Inc.
1700 E Walnut Ave
Fullerton CA 92831
(714) 441-2893
(714) 441-0525 FAX

PuROTwist



Reverse Osmosis System Installation & Service Guide



**Model #: PT3000T36-GOLD
DISCONTINUED**

Do not use with water that is microbiologically unsafe or of unknown quality without adequate disinfection before or after the system

Purotwist Manual Introduction

The Purotwist reverse osmosis drinking water system is designed for easy installation and maintenance. You will insure a successful installation as well as reliable operation by carefully reading this manual and following the operational guidelines. Please note that routine maintenance is essential to the longevity and performance of the system. Filters should be changed every six months (see below) depending on the quality of the feed water supply. **The Purotwist RO installation should comply with all state and local laws and regulations. Manufacturer recommends a TDS test every six months.** This reverse osmosis system contains a replaceable component critical to the efficiency of the system. Replacement of the reverse osmosis component should be with one of identical specifications, as defined by the manufacturer, to assure the same efficiency and contaminant reduction performance.

Necessary Installation Tools	
• Variable speed drill	• Teflon tape
• Relton Drill	• Small knife
• 1" hole saw	• Phillips screw driver

Recommended Filter & Membrane Replacement Schedule		
Filter/Membrane	Part #	Frequency
Carbon GAC Prefilter	Q5633	6 months
Carbon GAC Postfilter	Q5633	6 months
* RO Membrane	TQ56-35FC/NSF	2-5 years

Conditions for operation of TFC - Thin Film Composite Membrane Used in the PT3000T36-GOLD

Source Water Supply - TFC	
Community / Private	Bacteriologically Safe
System Pressure min/max	30 / 100 psi
Temperature	4° / 38°C (40° / 100° F)
pH Range	3.0 to 11.0
Maximum supply TDS level	2000 mg/L
Turbidity	< 1.0 net turbidity (NTU)

Chemical Parameters - TFC	
Hardness (CaCO ₃)	< 350 mg/L (< 20 gpg)
Iron (Fe)	< 0.1 mg/L
Manganese (Mn)	< 0.05 mg/L
Hydrogen Sulfide (H ₂ S)	0.00 mg/L
Production Rate	
¹ Efficiency Rate	12.5 %
² Recovery Rate	22.5 %
Daily Production Rate	17 gpd

Test parameters: 25± 1°C, 50 psi and pH of 7.5

¹ Efficiency rating means the percentage of the influent water to the system that is available to the user as reverse osmosis treated water under operating conditions that approximate typical daily usage

² Recovery rating means the percentage of the influent water to the membrane portion of the system that is available to the user as reverse osmosis treated water when the system is operated without a storage tank or when the storage tank is bypassed.

Caution: Do not use this system where the water is microbiologically unsafe or of unknown quality. This system is for use on potable water only. Source water exceeding the chemical parameters (listed above) requires pretreatment.

Starting Your Installation

STEP 1: Drilling the Faucet Hole

The product water faucet may be installed on any flat surface at least 2" in diameter. Check the underside of the location for interference.

Porcelain/Enamel Sinks

A 3/8" variable speed drill is recommended for this procedure. A spring loaded Relton style drill set is strongly recommended to prevent chipping.

The plastic sleeve supplied on the pilot drill is to be positioned on the drill bit against the drill chuck. This prevents the chuck from contacting the porcelain after the pilot hole has been completed.

Avoid high motor RPM during the initial cutting of the porcelain as this can cause chipping.

Using a carbide tipped drill bit, drill a pilot hole completely through the porcelain and the material underneath.

Place the spring loaded porcelain saw into the drill chuck. Make sure the pilot guide is inserted tightly. Insert the pilot guide into the pilot hole. Push down gently on the drill motor to apply light pressure to the porcelain surface. Start the drill motor turning as slowly as possible.

After the initial cut has started, motor speed may be gradually increased. The cut may require three to four minutes to complete. Going faster could result in excessive chipping. This saw is used to cut the porcelain only. Be sure a complete ring has been cut through the porcelain to the metal underneath.

Place the finish hole saw into the drill chuck. Make sure the pilot guide is inserted tightly. Insert the pilot guide into the pilot hole. Begin cut using a slow speed and light pressure until the metal has been penetrated.

Stainless Steel Sink

Make a small indent to mark the desired drilling location using a center punch. Drill a pilot hole with a 1/8" metal drill bit. Enlarge the hole using a 1" metal drill bit.

Tile Counter Top

Follow the procedures outlined in the Porcelain/Enamel Sinks section.

Faucet Installation

Once the hole has been drilled in the sink, the faucet may be located in the hole. Be sure the faucet body, faucet base, and the rubber faucet base washer are in place above the sink (See illustration on page 5). Install the star lock washer and nut, then tighten firmly while aligned faucet in the desired direction. Once the faucet is installed, screw the connector fitting provided onto the bottom of the faucet stem and tighten.

Drilling with the recommended Relton cutter

EASY AS . . .

1



The Pilot Drill is used to drill a hole completely through to provide a guide for both the Porcelain Saw and Finish Hole Saw.

2



The Porcelain Saw is used to cut through the porcelain surface only. This saw cuts a smooth, chip-free, beveled groove through the porcelain to the metal base.

3



The Finish Hole Saw is used to cut the remaining metal through to create the hole of the desired finish size.

Caution: Do not use this system where the water is microbiologically unsafe or of unknown quality. This system is for use on potable water only. Source water exceeding the chemical parameters requires pretreatment.

Tapping into the Cold Water Line

STEP 2: Shut Off the Water

Locate the water shut-off valve for the cold water feed line that you have chosen to use for the supply. **Accidentally hooking up the system to the hot supply line will permanently damage the membrane** (See Conditions for operation). To assure you are using the cold water line turn on both the hot and cold faucets. After the water is warm, feel the pipes underneath the sink to identify the hot and cold.

Close the cold water valve. Turn on the cold water faucet only to assure that the line is completely shut off and the line is drained. If no shut off valve is located under the sink, turn off the main supply at the entry to the house.

Place the clamp over the cold water supply line. The aluminum spacer has two sides to adapt to different tubing sizes. Use the small radius for 3/8" tubing and the large radius for tubing through 5/8". Use the clamp screw to attach the saddle to the copper pipe. Tighten the brass clamp screw with a 7/16" wrench.

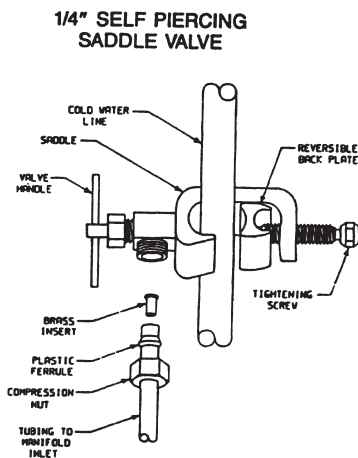

Do not over tighten the clamp. The clamp should be secure and resist a slight twisting force. Turn the saddle-tapping valve clockwise until the needle fully pierces the tubing and the valve seats. For maximum flow, back the handle out all the way. Adjust as required.

Check for Leaks

Turn on the cold water supply. Check the saddle-tapping valve for leaks. Allow the water to run for a minute to clear any possible debris from the saddle-tapping device. If flow from the faucet is reduced, remove, clean and reinstall the faucet aerator

STEP 3: Mounting the Tank Ball Valve

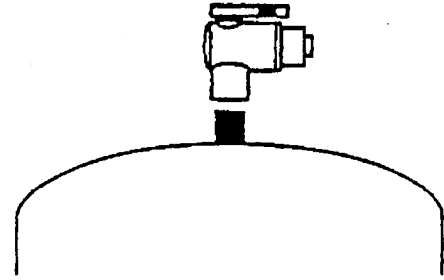

Note: Do not tamper with the air valve on the storage tank. It has been preset and screwed on with blue cap by the manufacturers.

- (1) Wrap the threads on the top of the water storage tank 3 times with plumbers (Teflon) tape only. Make sure it is tight, but not over tight.
- (2) Connect the tank ball valve assembly to the top of the water storage tank.
- (3) Connect the tube from the RO module to the water storage tank.

STEP 4: Installing the Drain Clamp

Select a location for the drain hole based on the design of the plumbing. Position the drain outlet saddle on the drainpipe. Allow adequate space for drilling. Tighten the bolts evenly on both sides. Avoid over tightening.

Using the opening in the drain outlet saddle as a guide, drill a 3/8" hole in the drainpipe. Clean debris from the saddle and threads.

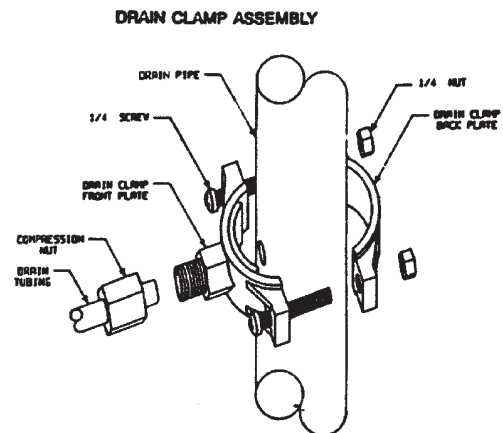

NOTE: Some states and provinces require the use of an air gap faucet. To assure compliance check your local plumbing code. Locate the drain connection away from the garbage disposal to prevent potential contamination and system fouling.

Mounting the Filters & Membrane

STEP 5: Mounting the Filters & Membrane

Screw the filters onto the mounting head starting from left to right in the order listed below, matching the filter label to the respective position labeled on the mounting head.

Important: Remove the black protective cap from the membrane before screwing in place.

Model	Carbon	Membrane	PostFilter
PT4000T36-GOLD	Q5640	TQ56-35FC/NSF	Q5640

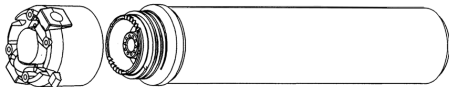

STEP 6: Tubing Connection

For RO Systems, determine the location for the storage tank. A maximum distance from tank to faucet is 15 feet. The fastest flow at the faucet can be achieved by minimizing the length of the tubing from tank to faucet.

For ease of installation all tubing is individually labeled and color coded.

1/4" Red - Connects the feed water valve to the pre-filter.

3/8" Blue - Connects the RO membrane product port to the storage tank.

1/4" Black - Connects the membrane drain port to 1/4" hosebarb fitting on airgap faucet.

3/8" White - Connects the postfilter to the faucet.

3/8" Black - Connects 3/8" hosebarb fitting on airgap faucet to drain connector.

STEP 7: Ice Maker Hook-Up (Optional)

If your refrigerator is less than 25 feet to your RO unit, 1/4" polypropylene plastic tubing is recommended. If your refrigerator is greater than 25 feet from your RO unit, 3/8" tubing is recommended. **Do not use copper tubing as an objectionable ice cube taste can result.**

To begin, install a tee in the white tubing between the final filter and the faucet. Next, it is recommended to install a ball valve in the line to the ice maker. This will allow storage tank pressure to increase sufficiently for the ice maker solenoid to operate properly. Leave the ball valve in the closed position until the tank is full after start up procedure is completed.

Fittings and Tubing

John Guest™ fittings are used throughout the system. To insure an optimal seal, tubing should be cut with the end square. An angled cut or distortion of the tubing will not provide an efficient seal and may cause leaks.

To install a tube, push it through the collet until it seats firmly. To remove a tube, push in the collet and pull out the tube.

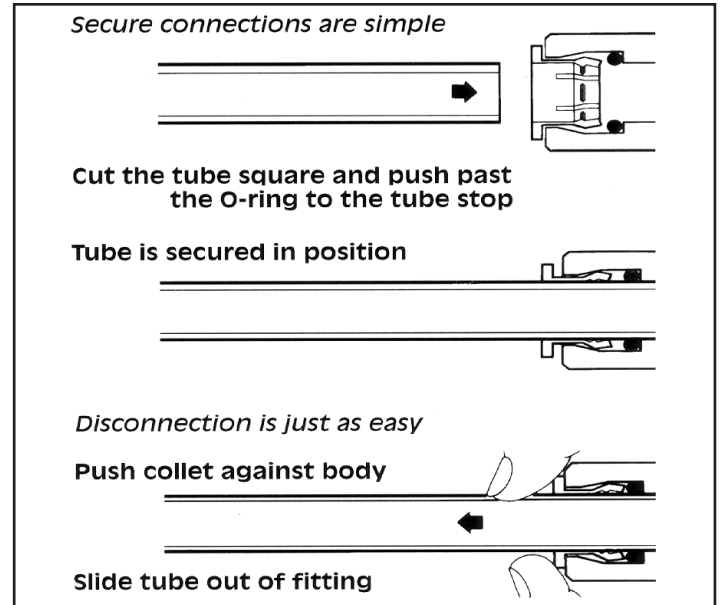

STEP 8: Activating System for the First Time

Make sure all water supply/drain lines are secure and free from leakage. Slowly turn the saddle valve counterclockwise until fully open.

Check stem seal for leakage. If necessary tighten stem nut lightly. Turn storage tank valve one quarter turn counterclockwise to open the valve (the handle should be in line with the tubing as it enters the connection).

Open the product water faucet and let the water flow until all the air has been expelled from the system. This will take about an hour for an RO system.

Close the product water faucet. In 30 minutes, check the connections for leaks and correct if necessary.

Do Not Use the First Two Reservoirs of Water.

Allow the reservoir to fill for 4-6 hours. Dispense this water to drain. This process removes the factory installed sanitizing solution from the entire system and sends it to the drain. Repeat this process one more time. Allow the tank to fill for 4-6 hours and dispense this water to the drain. (May take up to 24 hours of runtime [flushing] at start up or after a new membrane replacement, before system reaches optimum quality).

System and Faucet Diagrams

Good Water Warehouse Inc.

1700 E. Walnut Ave.

Fullerton, CA, 92831

Phone: 714-441-2893 Fax: 714-441-0525

PuROTwist System

PT000T36-GOLD

- 24 hour flush time -

Air Gap Faucet

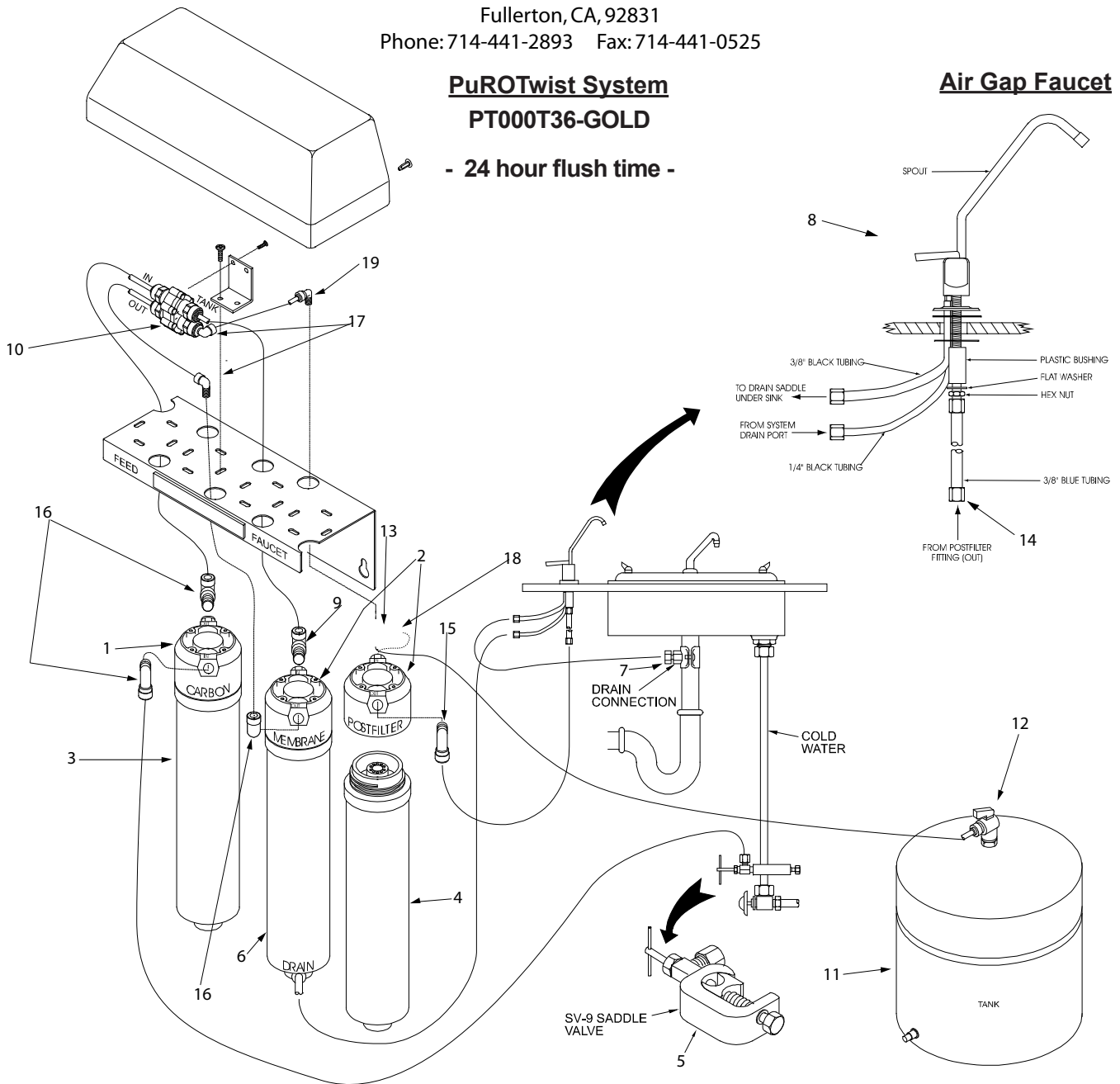

Please Call Your Local Water Professional For Parts Replacement

- | | | | |
|-------------------------------|---------------|-------------------------------------|-------------|
| 1. 1/4" Valved Head | VH1/4 | 11 3.2 Gallon Tank - White | TKE-3200W |
| 2. 1/4" Non-Valved Head | NVH1/4 | 12. JG 3/8 x 1/4 Female NPTF EL | PPSV501222W |
| 3. 2.5" x 12" T40 GAC; Quick | Q5640 | 13. JG 3/8 Union Tee | PI0212S |
| 4. 2.5" x 12" T40 GAC; Quick | Q5640 | 14. JG 3/8 x 7/16 UNS Faucet Co | CI3212U7S |
| 5. Feed Valve; C Style SP-1/4 | SVN6 | 15. JG 3/8 x 1/4 NPTF Fixed Elb | PI481222S |
| 6. Q TFC 36GPD Enc Mem w/FC | TQ56-36FC/NSF | 16. JG 1/4 x 1/4 Fixed Elb | PI480822S |
| 7. Drain Connector; 3/8 M.Co | PDC60438M | 17. JG 1/4 STM - 1/4 Tube Plug In | PI220808S |
| 8. AG Prop 65 LR Faucet-3" ,P | N103H3PIAG | 18. JG 3/8 STM x 1/4 NPTF Stem Adap | PI051222S |
| 9. SS Ck Valve; A4ME4 | SCV-A4ME4 | 19. JG 3/8 STM- 1/4 Tube Plug In | PI221208S |
| 10. Auto Shut Off Valve; JG-W | ASV-100JG | | |

Troubleshooting & Maintenance

Filter Maintenance

Filters should be changed every six to twelve months depending on the quality of the feed water supply.

RO System Maintenance

- 1) Open the RO faucet and let the tank drain completely. Leave the faucet open until the filter change is complete.
- 2) Remove the pre-sediment cartridge - Simply turn the pre-filter cartridge counterclockwise and remove it. This will automatically shut off the water supply at the RO.
- 3) Remove the pre-carbon cartridge - Simply turn the pre-filter counterclockwise and remove it.
- 4) Remove the membrane cartridge - The membrane may be reused indefinitely as long as the TDS level and other troubleshooting guidelines are met.
- 5) Remove the post-carbon cartridge - Simply turn the post-carbon cartridge counter-clockwise and remove it.
- 6) Install the new filters in the opposite order from removal.
- 7) Install the new pre-filter cartridge last. This will automatically turn on the system.
- 8) Drain the first tank of water after changing the filters before drinking. When the membrane is changed, drain the first two tanks of water before drinking

Troubleshooting		
Problem	Reason	Solution
Water has an offensive odor / taste	Carbon post filter is depleted	Drain storage tank & replace post filter
Water has an offensive odor / taste	Filters are depleted	Replace filters & sanitize system
Not enough product H ₂ O Pressure	Storage tank air pressure is low	Empty storage tank and set pressure to 8 psi (55kPa)
Not enough water	Low water pressure	If line pressure is below 30 psi install a booster pump
Not enough water	Water supply is blocked	Clear restriction, rotate valve on feed water
Not enough water	Storage tank is depleted	Consider an increase in tank or membrane capacity
Not enough water	Clogged pre-filter cartridge	Replace prefilter, drain tank and sanitize system
No drain water	Clogged flow restrictor	Replace membrane
No water	Water supply is turned off	Turn water on
Under sink is wet	Leak from valve, faucet or fitting	Dry everything with towels to isolate leak, identify and fix.

PuRO Twist Limited Warranty

Good Water Warehouse Inc. (GWW) warrants the reverse osmosis system to be free from defects in materials and workmanship under normal use within the operating parameters listed below. For a period of five years from the date of purchase, GWW will repair or replace any part of the reverse osmosis system with the exception of the filters, membrane and battery. The RO membrane carries a one-year warranty.

Conditions of Warranty

The above warranty shall not apply to any part of the reverse osmosis system that is damaged due to neglect, misuse, alteration, accident, misapplication, physical damage, fouling, and/or scaling of the membrane (by minerals, bacterial attack and/or sediment), fire, frozen water, hot water, or an Act of God.

Good Water Warehouse assumes no warranty liability in connection with this reverse osmosis system other than as specified herein. GWW shall not be liable for consequential damages of any kind or nature due to the use of Good Water Warehouse products.

Good Water Warehouse Inc. will provide warranty service under the following conditions:

- 1) Contact your local dealer who will obtain authorization and return instructions from GWW.
- 2) Ship the unit or part freight prepaid to Good Water Warehouse for warranty evaluation or service. Unit must be returned in the original carton or packaged to prevent possible damage. Systems or parts covered under the warranty shall be repaired (or, at our option, replaced) and returned without charge.

Conditions for operation TFC - Thin Film Composite

Chemical Parameters - TFC		Source Water Supply - TFC	
Hardness (CaCO ₃)	< 170 mg/L (< 10 gpg)	Community / Private	Bacteriologically Safe
Iron (Fe)	< 0.1 mg/L	System Pressure min/max	30 / 100 psi
Manganese (Mn)	< 0.05 mg/L	Temperature	4° / 38°C (40° / 100° F)
Hydrogen Sulfide (H ₂ S)	0.00 mg/L	pH Range	3.0 to 11.0
Production Rate		Maximum supply TDS level	2000 mg/L
Daily Production Rate	17 gpd	Turbidity	< 1.0 net turbidity (NTU)